

# M-S Dual Driver X12.014

## Features

- generates microsteps
- glitch filters on all inputs
- VDD = 4.5 to 5.5V
- low EMI emission

## Description

The M-S Dual Driver X12.014 is a monolithic CMOS device intended to be used as an interface circuit to ease the use of the Miniature Stepper Motors M-S X15.xxx. It was specifically designed for applications in the car dashboard. The circuit allows the user to drive two motors as it contains two identical drivers on the same chip.

The driver circuit converts a pulse train  $f(scx)$  into a current level sequence sent to the motor coils. This sequence is used to produce the microstepping movement of the motor. A microstep corresponds to an angular rotation of 1/12 deg. of the shaft. The microstepping allows for smooth and appealing movement of a pointer if the M-S is used as pointer drive. Note that the precision of the angular position is always affected by the gear play of the motor which is  $\pm 1/3$  deg.

## Applications

### Analogue Instrumentation

- car dashboard (Hybrid Instrument Cluster)
- nautical instrumentation
- aeronautical instrumentation

### Microrobotics

- appliance controls
- devices for medical analysis

## Typical Operating Configuration

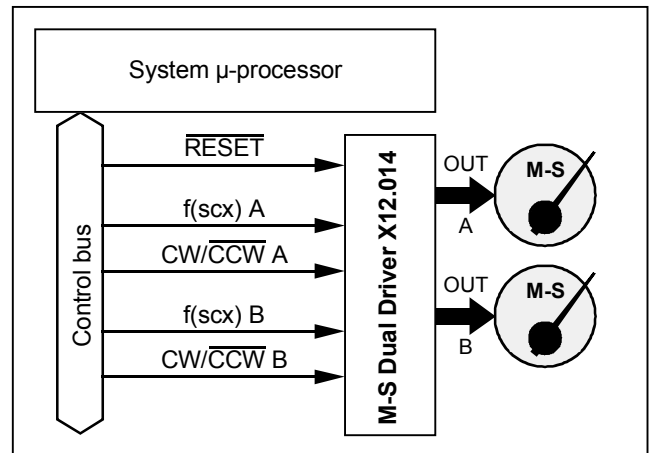

Fig. 1

## Pin Assignment

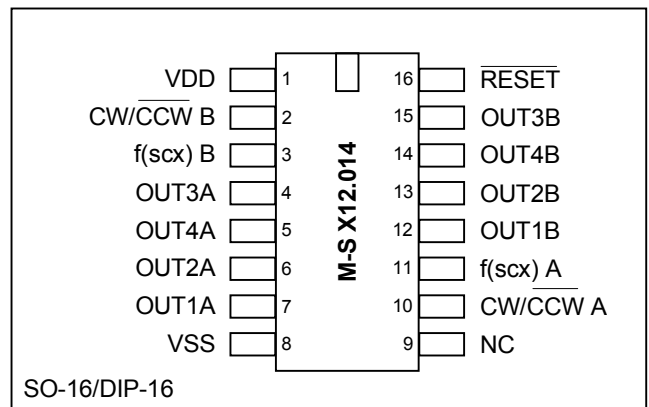

Fig. 2

## Absolute Maximum Ratings

Parameter	Symbol	Conditions
Voltage $V_{DD}$ to $V_{SS}$	$V_{DD}$	-0.3 to +6V
Voltage at any pin to $V_{DD}$	$V_{MAX}$	+0.3V
Voltage at any pin to $V_{SS}$	$V_{MIN}$	-0.3V
Current at OUTs 1-4	$I_{OUTMAX}$	$\pm 35$ mA
Max. junction temperature	$T_j$	150°C
Operating temp. range	$T_A$	-40 to +105°C
Storage temp. range	$T_{STO}$	-65 to +125°C

Table 1

Stresses beyond these listed maximum ratings may cause permanent damage to the device. Exposure to conditions beyond specified operating conditions may affect device reliability or cause malfunction.

## Operating Conditions

Parameter	Symbol	Test Conditions	Min	Typ	Max	Units
Operating temperature	$T_A$		-40		+105	°C
Thermal impedance	$R_{th\ j-a}$	DIP package SO package		66 86		°C/W °C/W
Supply voltage	$V_{DD}$		4.5	5	5.5	V
Input voltage at any pin	$V_{IN}$		$V_{SS}$		$V_{DD}$	V

Table 2

## Load Characteristics

Parameter	Symbol	Test Conditions	Min	Typ	Max	Units
Coil resistance	$R_{B25}$	M-S X15.xxx, $T_A=25^\circ\text{C}$	260	290	320	$\Omega$
	$R_{B-40}$	M-S X15.xxx, $T_A=-40^\circ\text{C}$	190			$\Omega$
	$R_{B105}$	M-S X15.xxx, $T_A=105^\circ\text{C}$	340			$\Omega$
Phase inductance	$L_{25}$	M-S X15.xxx, $T_A=25^\circ\text{C}$		0.4		H

Table 3

## Electrical Characteristics

$V_{DD} = 4.5 \div 5.5\text{V}$ ,  $T_A = -40 \div 105^\circ\text{C}$ , unless otherwise specified

Parameter	Symbol	Test Conditions	Min	Typ	Max	Units
<b>Power Consumption</b>						
Typical supply current	$I_C$	$V_{DD}=5\text{V}$ , $\omega=200^\circ/\text{s}$ , $T_A=25^\circ\text{C}$ , $R_{B25}=290\Omega$		38		mA
Worst case supply current	$I_{CMAX}$	$V_{DD}=5.5\text{V}$ , $\text{RESET}=V_{SS}$ , $T_A=-40^\circ\text{C}$ , $R_{B-40}=190\Omega$			100	mA
Quiescent supply current	$I_{CC}$	All inputs at $V_{DD}$ or $V_{SS}$ , no load			300	$\mu\text{A}$
<b>Inputs</b>						
Low level input voltage	$V_{IL}$	$V_{DD} = 4.5 \div 5.5\text{V}$	$V_{SS}$		1.35	V
High level input voltage	$V_{IH}$	$V_{DD} = 4.5 \div 5.5\text{V}$	3.15		$V_{DD}$	V
Input leakage	$I_{IN}$	$V_{IN} = V_{SS}$ or $V_{DD}$	-10		10	$\mu\text{A}$

Table 4

## Timing Characteristics

$V_{DD} = 4.5 \div 5.5V$ ,  $T_A = -40 \div 105^\circ C$ ,  $t_{rise}$  and  $t_{fall} \leq 20ns$ , input signal swing  $V_{SS}$  to  $V_{DD}$

Parameter	Symbol	Test Conditions	Min	Typ	Max	Units
Signal pulse width	$t_w$	high or low	450			ns
Input frequency	$f(scx)$	Driver input limit Motor speed limit ( $\omega=600^\circ/s$ )			1.1 7.2	MHz kHz
Setup time to $f(scx)$	$t_s$	high or low	100			ns
RESET release time to $f(scx)$	$t_{rr}$		100			ns

Table 5

## Delay Timing Waveforms

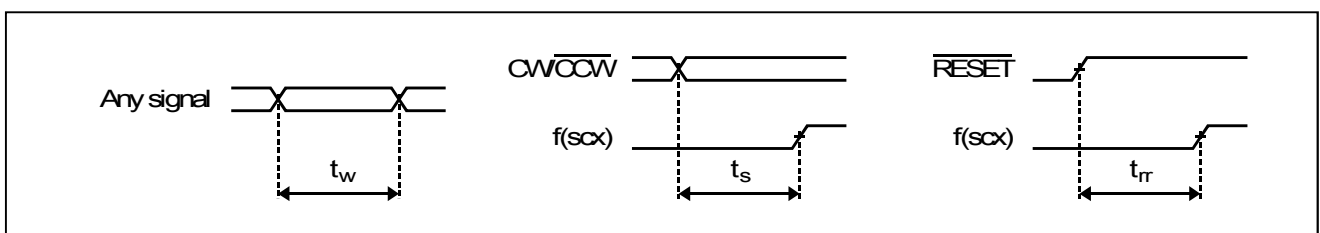

Fig. 3

## Pin Description

Unused inputs must always be tied to a defined logic voltage level unless otherwise specified

Pin Number DIP/SOL 16 Version	Name	I/O	Function
1	VDD	V	Positive supply voltage
8	VSS	V	Negative supply voltage
11 / 3	$f(scx)$ A / B	I	Stepping frequency; Driver A / B
10 / 2	CW/CCW A / B	I	Direction of rotation; Driver A / B
16	RESET	I	Reset for the two drivers
7 / 12	OUT 1A / 1B	O	Coil output 1; Driver A / B
6 / 13	OUT 2A / 2B	O	Coil output 2; Driver A / B
4 / 15	OUT 3A / 3B	O	Coil output 3; Driver A / B
5 / 14	OUT 4A / 4B	O	Coil output 4; Driver A / B

Table 6

## Circuit Protections

To filter fast voltage transients, it is highly recommended to connect one 100nF ceramic capacitor to the power supply pins, as close as possible to the IC.

Moreover, to protect the IC against latch-up, a 5 $\mu$ F capacitor per motor connected should be added. Thus, for 2 motors, typically a 10 $\mu$ F capacitor must be used, either electrolytic or tantalum. Note this capacitor can be placed close to the voltage regulator.

## Recommended Power Up

In order to power up the circuit in a defined manner, it is recommended to keep the RESET input low while the VDD voltage is raising. After a delay of about 1ms, the RESET can be released (i.e. set high).

Depending on the microcontroller used, an external pull-down resistor might be required to properly set the RESET state at low during the start-up.

**Block Diagram**

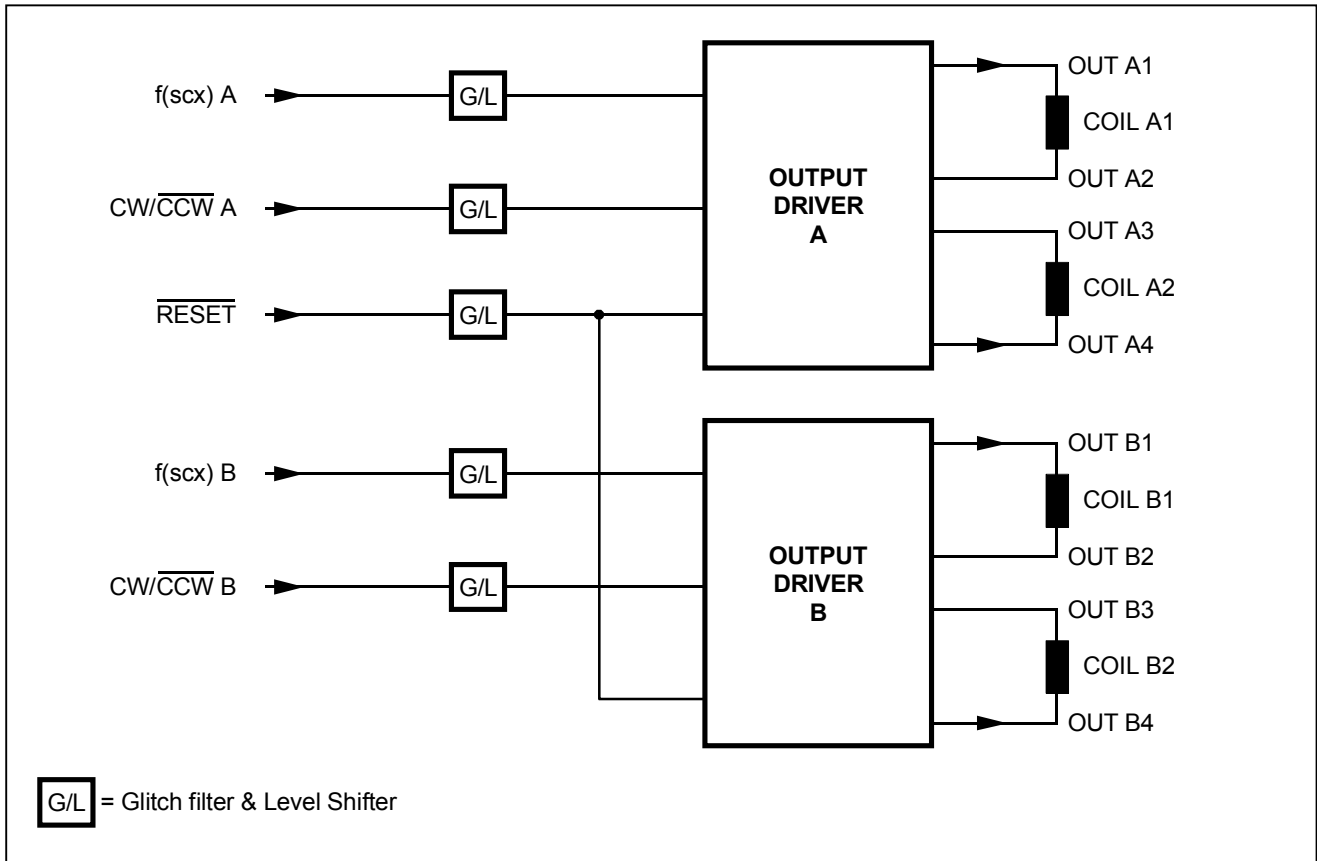

Fig. 4

**Suggested Applications**

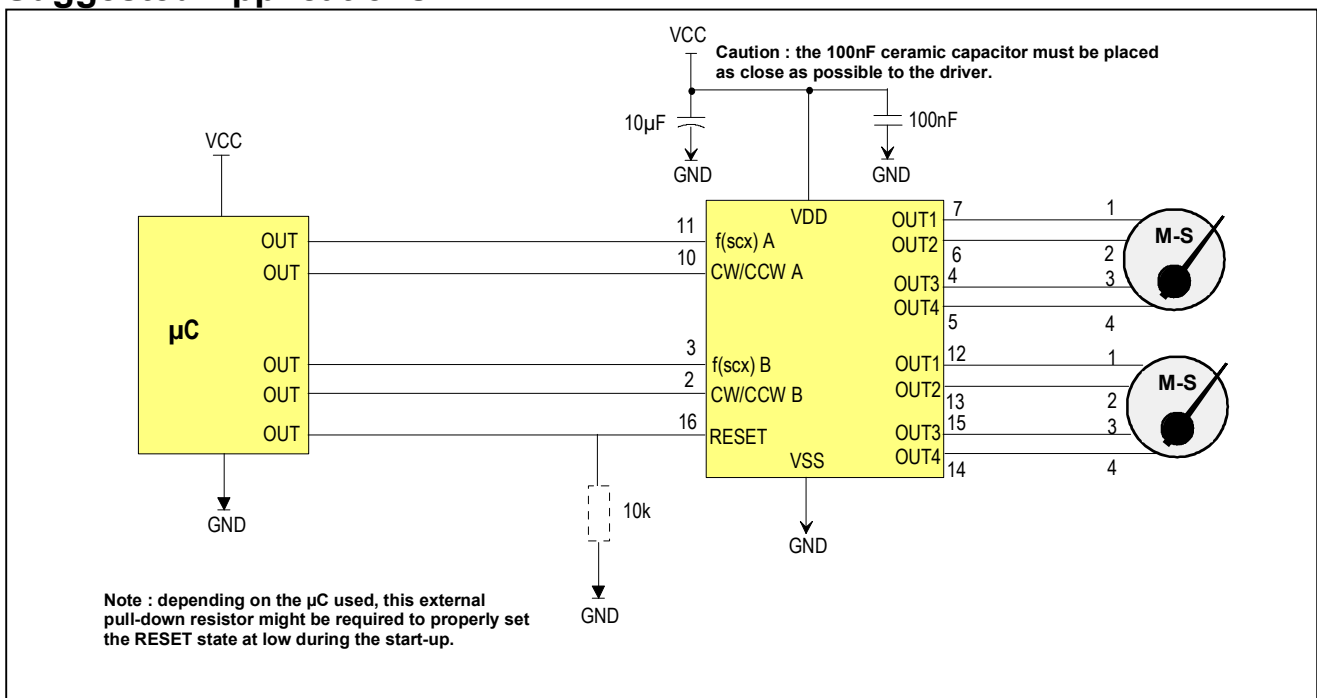

Fig. 5

## Functional Description

- The rising edge of the f(scx) input signal moves the rotor by one microstep.
- The input signal "CW/CCW" (clockwise / counter-clockwise) controls the direction of rotation of the motor.
- The input signal "RESET" at low resets the output driver sequence to position 1.

## Rotor Positions

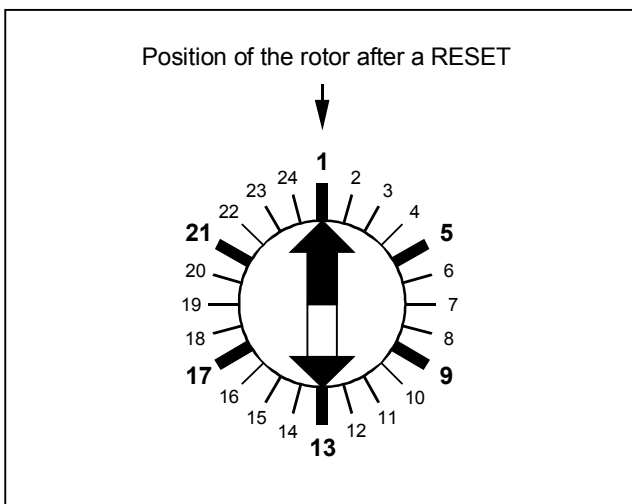

Fig. 6

## M-S Stepping Modes

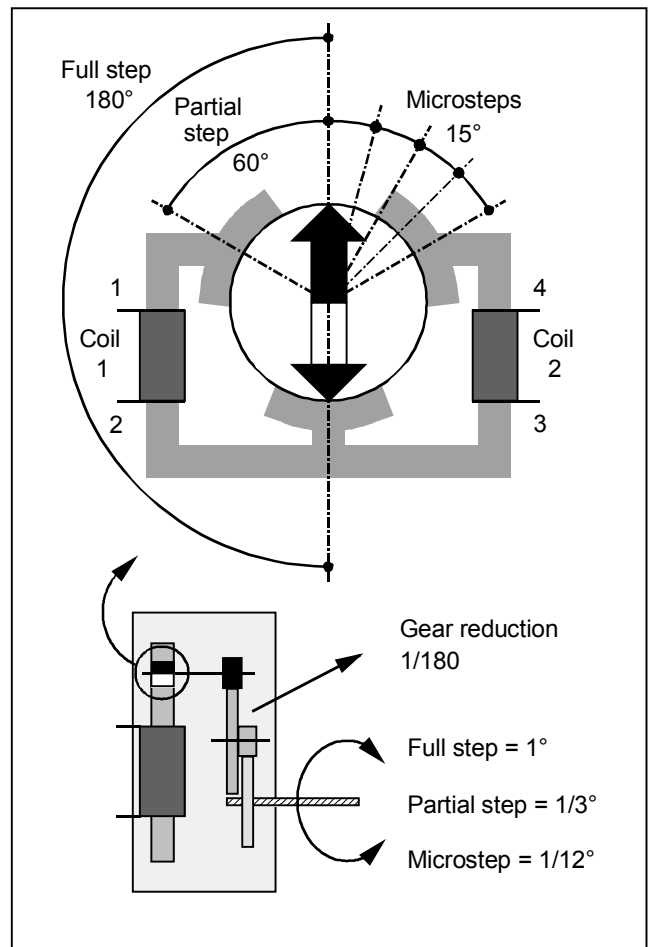

Fig. 7

## Input Glitch Filter & Level Shifter

All logic inputs of the M-S Dual Driver are armed with a glitch filter to avoid erroneous information due to spikes and glitches on the input signal lines. All negative or positive pulses of less than 20 ns width are ignored.

A minimum signal pulse width (positive or negative) of 450 ns guarantees correct function over the full temperature range.

All logic inputs also feature a level shifter, which allows for operation of the circuit at a higher supply voltage ( $V_{DD}$ ) than the circuits driving the inputs. This is in order to drive the M-S motors at a higher torque level.

## The Output Driver

The output driver converts the pulse train of f(scx) into a current level sequence sent to the two motor coils of the M-S. This sequence of 24 current levels per rotor revolution is used to produce the microstepping movement of the rotor.

A microstep is an angular rotation of 1/12 deg. of the M-S shaft or 15 deg. on the rotor shaft.

A partial step is an angular rotation of 1/3 deg. of the M-S shaft or 60 deg. on the rotor shaft.

A full step is an angular rotation of 1 deg. of the M-S shaft or 180 deg. on the rotor shaft.

The microstepping allows for smooth and appealing movement of a pointer if the M-S is used as pointer drive. It is not intended as a precise positioning. The precision of the angular position is given by the resolution of the partial step.

## Dimensions of DIP Package

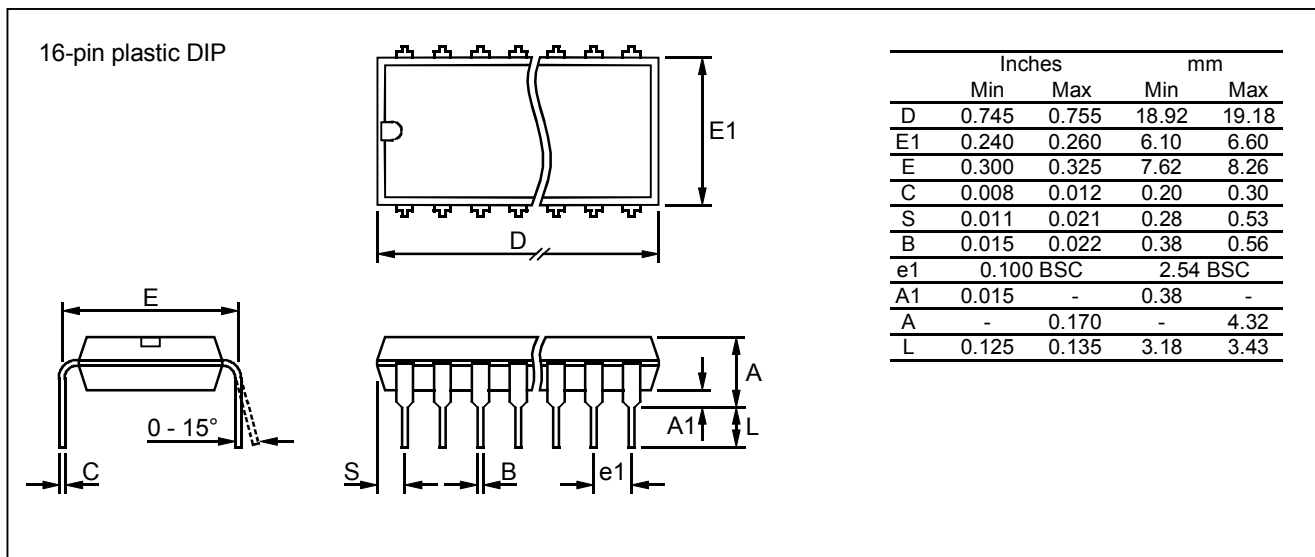

Fig. 8

## Dimensions of SOL Package

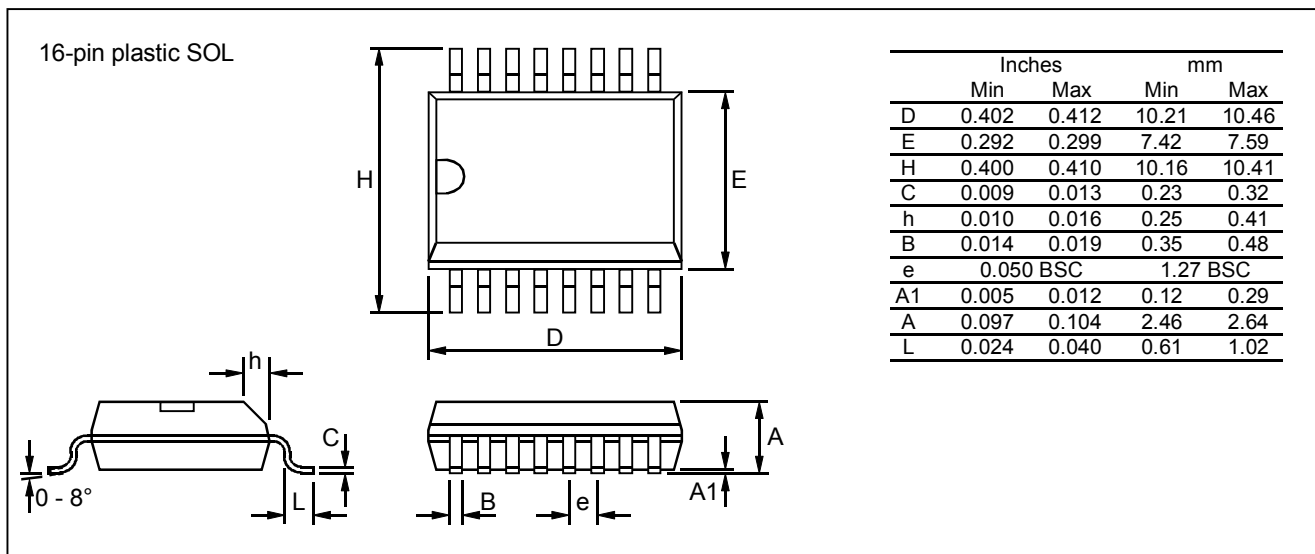

Fig. 9

## Ordering Information

The M-S Quad Driver X12.014 is available in the following packages:

- DIP 16-pin plastic package
  - SOL 16-pin wide plastic package
- M-S Dual Driver X12.014 – DIP16  
M-S Dual Driver X12.014 – SOL16  
(Available on reel)

Chip form on request.

When ordering, please specify the complete part number and package.

Special feature: These products from Jan. 2006 are in conformance to RoHS and Green mold regulations.

## Table of Contents

M-S Dual Driver X12.014 .....	1	Circuit Protections .....	3
Features .....	1	Recommended Power Up.....	3
Description .....	1	Block Diagram.....	4
Applications.....	1	Functional Description .....	5
Typical Operating Configuration.....	1	Rotor Positions.....	5
Pin Assignment .....	1	Input Glitch Filter & Level Shifter .....	5
Absolute Maximum Ratings .....	2	M-S Stepping Modes .....	5
Handling Procedures.....	2	The Output Driver .....	5
Operating Conditions .....	2	Dimensions of DIP Package.....	6
Load Characteristics .....	2	Dimensions of SOL Package.....	6
Electrical Characteristics.....	2	Ordering Information.....	6
Timing Characteristics .....	3	Revisions .....	8
Delay Timing Waveforms.....	3	Approval.....	8
Pin Description .....	3	Distribution .....	8

The information and specifications given here are correct and valid to the best of our knowledge. However **switec**™ assumes no liability for damages which may arise through the incorrect use of this information or for eventual damages to existing patents or to the rights of third parties. The general purchase conditions for electrical and mechanical products of **switec**™ apply to all commercial transactions.

**switec**™ reserves the right to make changes in the products contained in this document in order to improve design or performance and to supply the best possible products.

**switec**™ is a trade mark of the Swatch Group Management Services AG.